

MODEL MV85-2

2 CUBIC FOOT UNDERCOUNTER ULTRA-LOW FREEZER

	WIDTH	DEPTH	HEIGHT	WIDTH	DEPTH	HEIGHT
INTERIOR DIMENSIONS	14 IN	18 IN	12.5 IN	36 CM	46 CM	32 CM
EXTERIOR DIMENSIONS	23 IN	27 IN	32 IN	60 CM	70 CM	81 CM
CRATED DIMENSIONS	32 IN	28 IN	41 IN	81 CM	71 CM	104 CM

SIDE VIEW

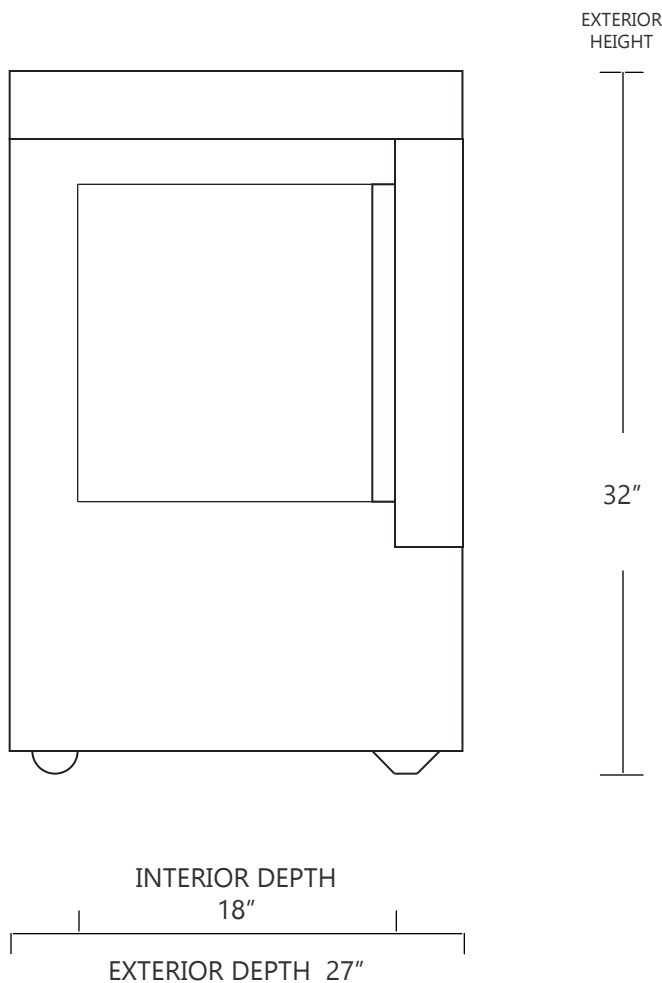

FRONT VIEW

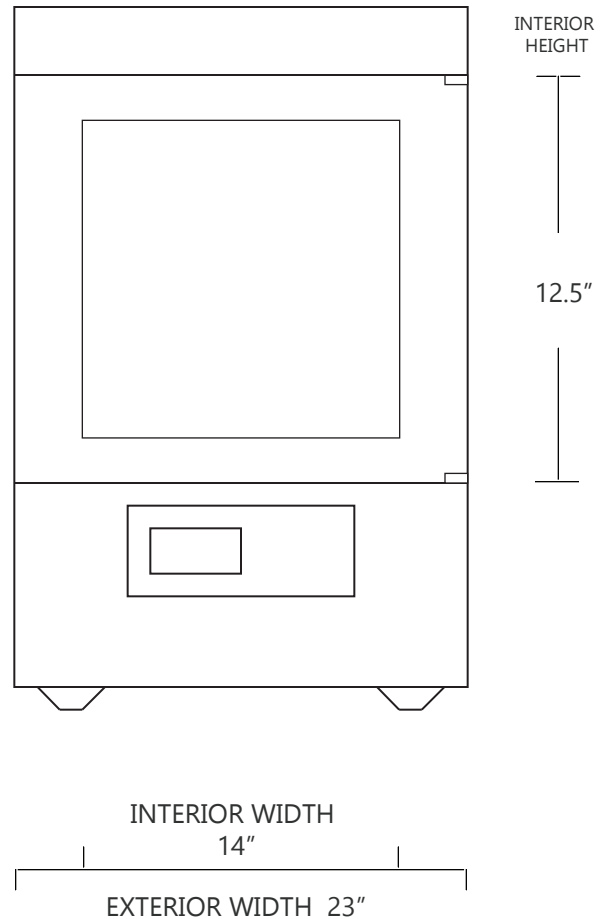

SO-LOW

WWW.SO-LOW.COM



NET WEIGHT : 190 LBS.
SHIPPING WEIGHT: 220 LBS.

SHIPPING OPTIONS

DOCK-TO-DOCK DELIVERY (REQUIRES FORKLIFT OR PALLET JACK)
DOCK-TO-DOCK DELIVERY WITH LIFTGATE (REQUIRES FORKLIFT OR PALLET JACK)
INSIDE DELIVERY (WHITE GLOVE DELIVERY)