INSTALLATION, OPERATION AND SERVICE INSTRUCTIONS

FOR CIRCULAR CHART RECORDERS

CoBEX RECORDERS, INC.

CAUTION: IT IS IMPORTANT THAT THESE INSTRUCTIONS BE READ BEFORE INSTALLING THE INSTRUMENT. KEEP THESE INSTRUCTIONS ON FILE FOR FUTURE REFERENCE.

RECEIVING INSPECTION

As soon as the recorder is received, visually inspect the shipping container for signs of damage. If there is evidence of rough handling, inspect the recorder immediately to make certain that it is intact and has not been damaged in shipment.

TRANSIT LOSS

All COBEX instruments are insured against transit loss by breakage. To make this insurance effective, all claims must be filed with the carrier at the destination within one week of receipt of merchandise. No claims, regardless of the nature of same, will be accepted beyond this period.

UNPACKING

Each recorder is shipped with the standard accessory items listed below. When unpacking the recorder make certain that all of the items are accounted for.

1. Charts: One box (where applicable).
2. Battery (for optional battery backed-up units).
3. Installation manual.

CoBEX RECORDERS, INC.

6601 LYONS ROAD, F-7
COCONUT CREEK, FL 33073
TEL. (954) 425-0003
FAX. (954) 425-0509
www.cobexrecorders.com

RECORDER CASE LOCATION

Upon unpacking, find a suitable location to mount the unit before plugging it in. After the recorder has been connected to the main AC power supply, connect the battery to the battery strap and place the battery in its holder (if your unit is equipped with an optional battery back-up).

Select a location that is well lighted, free from dust, dirt and corrosive fumes. The instrument should not be located near any sources of heat or be subjected to sudden or extreme temperature changes. It should be mounted on a rigid support that is not subject to vibration. Refer to Figures 7 and 8 for recorder case dimensions.

POWER SUPPLY

The recorder uses AC power when the unit is operating normally. If the AC power were to fail and the battery back-up option is installed, then the green LED light will begin "flashing" to indicate that there is an interruption in the main power. Otherwise, the green LED light glows continuously.

The recorder will have either an AC power cord or a wall mounted transformer for connection to the main AC power supply. If a permanent connection to the main AC power supply is to be accomplished in the field, then refer to Figures 6A, 6B, 6C and 6D for diagrams showing the connection to a 115VAC 50-60Hz or a 230VAC 50-60Hz main power supply.

CONNECTING A PROBE

Most of the temperature recording units will already have a temperature indicating probe installed. If the recorder has a Temperature/Humidity type probe, make sure to remove the protective cap when the recorder is in use and replace the cap whenever the environmental chamber is to be rinsed.

If you will be supplying your own probe input device, then this next section will contain some important

information concerning the connection of the probe to the recorder.

This recording unit is capable of accepting input from either a CURRENT source (such as 4-20mA), a VOLTAGE source (such as 0-1 Volt, 0-5 Volts, 1-5 Volts or 0-10 Volts) or a 100 ohm RTD probe. **Note:** The recorder is programmed (at the factory) to accept a specific probe input range. Connecting a probe that supplies the recorder with a current or voltage that is not within the specified range will give unpredictable results and may damage the recorder. If you are not sure of the probe type or input range for your recorder, please contact COBEX Recorders before continuing.

In order to connect the probe input device to the recorder, you must first gain access to the main microprocessor PC board that is mounted to the back of the chart plate.



CAUTION! DO NOT TOUCH the terminals of the transformer while the unit is connected to the main AC power supply. To avoid the risk of possible electric shock, unplug or disconnect the recording unit from the main power supply before attempting to open the recorder. If the recorder is installed with the battery back-up option, disconnect the 9 Volt battery to avoid damaging the recorder and draining the battery.

On 6" inch recording units mounted in a metal enclosure, the chart plate on the recorder case is held by four (4) screws. Unscrew and gently remove the chart plate to expose the main microprocessor PC board of the recording unit. Otherwise, your recording unit will have a hinged chart plate held in place by two (2) screws located in the upper and lower right hand corners of the chart plate. Remove these two screws and open the hinged chart plate. On 8" enclosures, there is a single screw along the right hand edge that secures the chart plate inside of the enclosure. Loosen this screw and open the hinged chart plate.

If you are not sure how to access the back of the chart plate, please contact COBEX Recorders before continuing.

Next, you will need to determine the *type* of microprocessor controller PC board that is installed in your recorder. Refer to Figures 1A, 1B and 1C and compare these figures to the microprocessor controller PC board that is installed in your recorder.

TYPE "A" CONTROLLER PC BOARD

If your recorder has a **Type A** microprocessor controller PC board installed, then locate screw terminal blocks J6 and JP5. Screw terminal block J6 is normally used when connecting an RTD temperature probe and JP5 is normally used to supply a signal input to the recorder from a VOLTAGE or CURRENT type probe. JP5 may also be used when connecting a second RTD temperature probe (on a two pen recorder). Refer to Figure 1A for the location of J6 and JP5 on the microprocessor PC board.

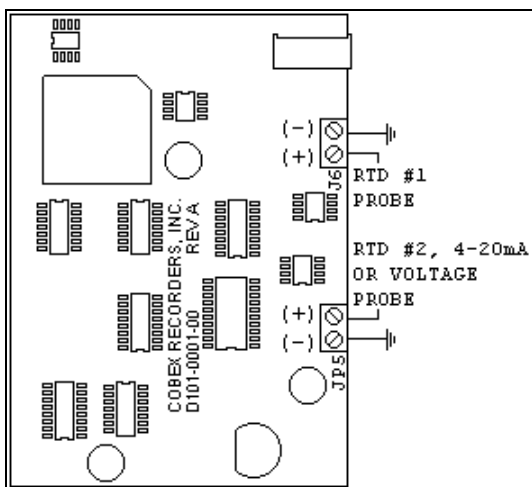

Figure 1A: Microprocessor PC Board (Type "A").

TYPE "B" CONTROLLER PC BOARD

If your recorder has a **Type B** microprocessor controller PC board installed, then locate screw terminal blocks J3 and J4 on the microprocessor PC board. These screw terminal blocks are used to provide signal input to the recorder for up to two pens. Refer to Figure 1B for the location of J3 and J4 on the micro-controller PC board. VIN (located on screw terminal block J4) is used to provide a signal input to the recorder from a VOLTAGE type probe, +5V can be used to power an external probe.

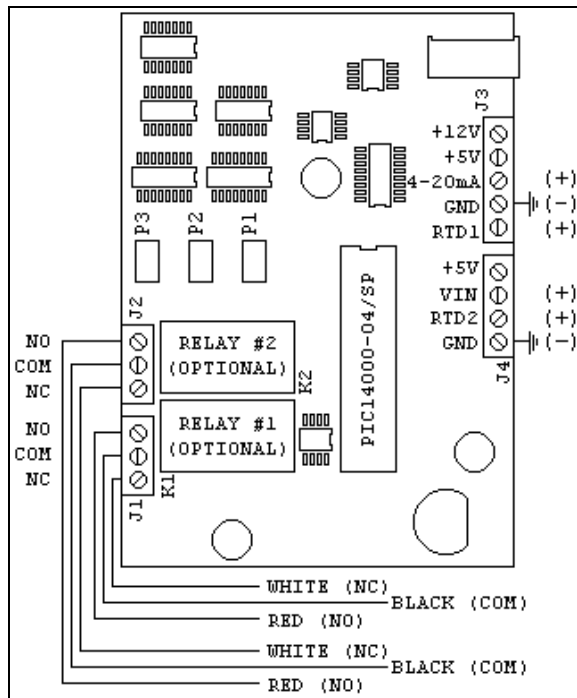

Figure 1B: Micro-Controller PC Board (Type B).

TYPE "C" CONTROLLER PC BOARD

If your recorder has a **Type C** microprocessor controller PC board installed, then locate screw terminal block J3 on the microprocessor PC board. This screw terminal block is used to provide a signal input to the recorder for one pen. Refer to Figure 1C for the location of J3 on the micro-controller PC board.

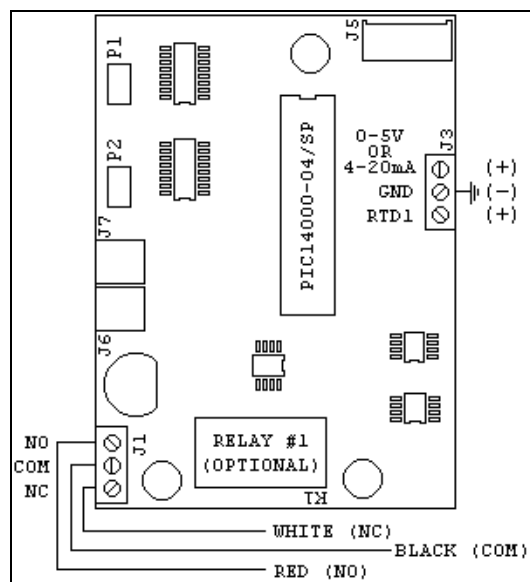

Figure 1C: Micro-Controller PC Board (Type C).

CHANGING THE CHART PAPER

Press and hold the "change chart" button (#3) for approximately one (1) second until the pen begins to move to the left of the chart and then release the button. Wait until the pen has moved completely off of the chart. To remove the chart paper, unscrew (counter-clockwise) the chart "hub" knob at the center of the chart. Remove the old chart paper and position the new one so that the correct time line coincides with the time line groove on the chart plate. Refer to Figure 5 for the location of the time line groove.

Re-attach the chart "hub" knob and screw securely (by hand) against the chart. Press and hold the "change chart" button (#3) again for approximately one (1) second until the pen begins to move back onto the chart and then release the button. Check to make sure that the pen is marking on the chart paper. If it is not, then carefully adjust the pen arm to establish contact with the paper.

MARKING SYSTEMS: MARK-A-MATIC II INKING SYSTEM

This type of pen consists of a self contained ink reservoir with a porous plastic stylus which is snapped around the outer edge of the metal pen arm.

A pen cap is provided to extend the life of the ink pen during shipping or when the recording unit is not in service. To remove the pen cap, gently lift the pen arm away from the chart paper. Remove the black plastic pen cap to expose the fiber tip of the ink pen and gently place the pen back onto the chart paper. Do not let the pen arm "snap" back onto the chart paper. This will flatten the fiber tip of the pen and will no longer give you a fine line marking on the chart paper. Place the pen cap in a safe place for future use.

If the stylus does not touch the chart, adjustment can be made by slightly bending the metal pen arm in the center towards the chart paper. Do not use more pressure than is necessary to create a fine line marking on the chart paper. **Note:** As the pen ink supply runs

out, the pen color will become lighter. This indicates that the pen should be replaced.

REPLACEMENT OF PEN

Note: In non-inking units, (that is, when using pressure sensitive recording chart paper) replacement of the pen is not necessary.

Recorders that are equipped with fiber tipped cartridge pens will have a cartridge that is color coded "red" to designate pen number one (1) and an optional cartridge that is color coded "blue" to designate pen number two (2). The pen cartridge is securely fastened to the metal pen arm using a special "U" clip tab.

For ease of replacement, it is suggested that the two (2) screws that hold the pen arm be loosened and the pen cartridge and metal pen arm be removed as an assembly. Refer to Figure 5 for the location of the pen arm screws. Unsnap the plastic "U" clip tab of the pen cartridge from the metal pen arm, remove and discard the old pen cartridge. Replace the new cartridge by opening the hinge and snapping it securely around the metal pen arm. Refer to the following figure.

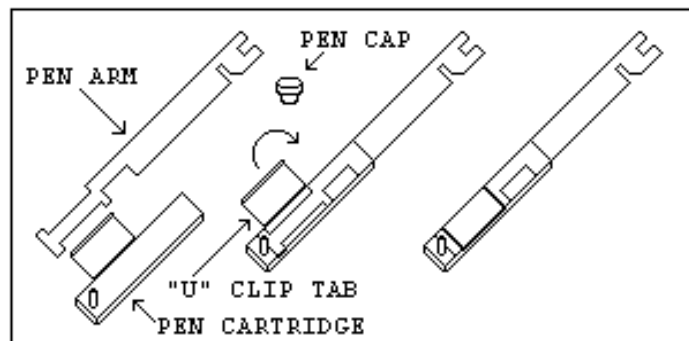

Figure 2: Pen Arm Assembly.

PEN ARM CALIBRATION

To check and/or adjust the recording pen(s) calibration to the outer most temperature graduation of the chart, press and hold the "change chart" button (#3) until the pen begins to move off of the chart. Once the pen(s) has moved off of the chart, again press and hold the "change chart" button (#3) until the pen begins to move back onto the chart. The pen

should briefly stop at the outer most temperature graduation of the chart before continuing onto the chart to begin recording. If the pen does not stop exactly at this location on the chart, it can be adjusted or "calibrated" by using the left (#1) or right (#2) arrow buttons (refer to Figure 3).

When the pen moves back onto the chart and briefly stops, you will have approximately five (5) seconds in which to adjust the pen's position using the left and right arrow buttons of Figure 3.

On multiple pen recorders, each pen will move (one-at-a-time) onto the chart briefly stopping at the outer most temperature graduation of the chart at which time the pen's position can be adjusted by using the left (#1) or right (#2) arrow buttons. When the time to adjust the position of the first pen has expired, the second pen will move onto the chart briefly stopping at the outer most temperature graduation of the chart at which time the second pen's position may be adjusted.

Each time the chart paper or fiber tip pen cartridge is changed, you should make sure that each pen stops at the outer most temperature graduation of the chart paper. Otherwise, this pen *offset* will cause the unit to record an incorrect temperature on the chart.

TEMPERATURE RECORDER CALIBRATION CHECK

This recorder has been accurately calibrated at the factory. Before making any adjustments, this instrument should be in service for 24 hours. Thereafter, if any adjustment is required, perform the following procedure. **Important: DO NOT immerse a Temperature/Humidity probe in any solution.**

1. Place a Certified Test Thermometer(s) in a solution bottle(s) alongside the recorder's sensor probe(s).
2. Once the temperature has leveled out, compare the position of the pen on the recorder to the test thermometer's reading.

- 2a. For two (2) pen recorders, also compare the second thermometer's reading to the second pen of the recorder.
3. If an adjustment is required, use the left (#1) and right (#2) arrow push buttons on the recorder to calibrate (or move) the pen's position on the chart to correspond to the temperature of the solution. The arrow buttons must be held for approximately five (5) seconds before the pen will begin to move.
- 3a. For two (2) pen recorders, you must first select the pen that you wish to calibrate. This is done by pressing the left (#1) arrow button to select the red pen or the right (#2) arrow button to select the blue pen. The arrow button must be held down until the green LED light goes out. After the green LED light goes out, follow the instructions in step #3 above. (Refer to the following figure for a diagram of the push buttons).

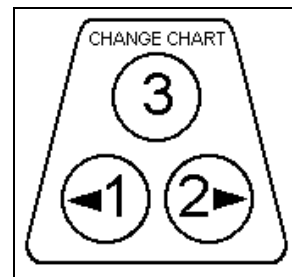

Figure 3: Push buttons.

OPTIONAL FEATURES

BATTERY BACK-UP

The green LED light remains a constant green color indicating that both the battery and the main power to the unit are good. Refer to Figure 5 for the location of the green LED indicating light. If the AC power were to fail or the battery becomes weak, then the green LED light will begin "flashing" indicating that either you have lost the main power to the unit or it is time to replace the battery. Having a 9 volt DC battery back-up in place, will allow the recorder to continue to function normally for approximately 24 hours in the event of a power failure.

BATTERY LOCATION AND REPLACEMENT

4", 6" AND 10" RECORDERS

To replace the battery, first open the recorder door. The battery will be located in the upper right hand corner of the unit. Refer to Figure 5 for the location of the battery. **Note:** Use only NEW 9 volt alkaline replacement batteries.

8" RECORDERS



CAUTION! DO NOT TOUCH the terminals of the transformer while the unit is connected to the main AC power supply. To avoid the risk of possible electric shock, unplug or disconnect the recording unit from the main power supply before changing the battery.

To replace the battery on an 8" recorder, first open the recorder case door. Next, loosen the single screw located on the right hand side of the chart plate and open the hinged chart plate. The battery strap and battery holder are located on the back of the chart plate. **Note:** Use only NEW 9 volt alkaline replacement batteries.

OPTIONAL ALARM/CONTROL RELAY CONNECTION TO THE RELAY



CAUTION! DO NOT TOUCH the terminals of the transformer while the unit is connected to the main AC power supply. To avoid the risk of possible electric shock, unplug or disconnect the recording unit from the main power supply before attempting to access the terminals of the relay. If the recorder is installed with the battery back-up option, disconnect the 9 Volt battery to avoid damaging the recorder and draining the battery.

On 6" inch recording units mounted in a metal enclosure, the chart plate on the recorder case is held by four (4) screws. Unscrew and gently remove the

chart plate to expose the relay that is mounted to the back of the chart plate. Otherwise, your recording unit will have a hinged chart plate held in place by two (2) screws located in the upper and lower right hand corners of the chart plate. Remove these two screws and open the hinged chart plate. On 8" recording units, there is a single screw along the right hand edge that secures the chart plate inside of the enclosure. Loosen this screw and open the hinged chart plate to expose the relay terminals. If you are not sure how to access the relay terminals of your recording unit, please contact COBEX Recorders before continuing.

The relays that are used in this recording unit are *latching* type relays. That is, the contacts of the relay will remain either closed or open (even when there is no power applied to the recorder) until the relay is pulsed with a signal from the recorder to change the position of the contacts.

Refer to Figures 1B, 1C and 6B for the location of the screw terminal connections for the relays. **Note:** A RED, BLACK and WHITE set of wires may already be provided as an external connection to the relay's terminal block. The terminal position NC will be *closed* when the pen is positioned to the right of the control point and will be *open* when the pen is positioned to the left of the control point.

The relays are rated for the following maximum values:

2.0 AMP at 30V DC
0.6 AMP at 125V AC
0.6 AMP at 110V DC

Warning: Damage to the recording unit may result if the ratings for the relays are exceeded.

SETTING THE CONTROL POINT FOR THE RELAY

To set the position of the pen on the chart that will determine when the relay contacts will open or close, follow these instructions:

Press and hold the "change chart" button (#3) until the pen arm begins to move off of the chart and then release the button. Wait until the pen has moved completely off of the chart. When the "change chart" button (#3) is pressed again, the pen will begin to move back onto the chart briefly stopping at the outermost graduation of the chart.

The pen arm will then move to the first control point position and the green LED light will turn off. The pen will remain at this position for a period of approximately five (5) seconds during which time the control point can be adjusted using the left arrow (#1) or the right arrow (#2) push buttons. Refer to the following figure for a diagram of the push buttons. When the time has expired for adjusting the control point, the green LED light will turn back on and the unit will begin recording.

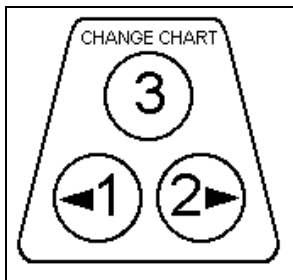

Figure 4: Push buttons.

When the pen has two control points, the pen then moves to the second control point at which time the second control point may be adjusted. Having two control points (per pen) allows you to define HIGH and LOW temperatures that will open or close the relay contacts. Approximately five (5) seconds after you have finished adjusting the control point(s), the LED light will turn solid green and the pen arm will move to indicate the probe's temperature and the unit will begin recording.

CHART "RANGE" SELECTION

If the recorder that you are using has a *range sticker* (that lists several temperature ranges) mounted on the front of the chart plate, then the following section will apply to you.

This recording unit has the option for the user to select from several temperature "ranges" that are programmed into the recorder. **Note:** The chart paper that is used on the recording unit must match the *range* that is selected for the recorder. Otherwise, the pen's position on the chart paper will not correspond to the temperature that is measured.

Also, if the pen moves to the center or outer edge of the chart and remains there while the unit is powered on, then this may be an indication that the current range that is selected for the unit is not correct. The recorder has a built-in safety mechanism that will always move the pen to the highest temperature on the chart when the current temperature that is measured is not within the selected range.

The recording unit can have up to eight (8) user selectable ranges programmed into the unit. To select from one of the available ranges, follow these instructions:

After the recording unit has been powered-on and is operating normally (recording temperature), press and hold the "change chart" button (#3) until the pen arm begins to move off of the chart. Once the pen has moved off of the chart, press and hold the left arrow (#1) or right arrow (#2) button for approximately eight (8) seconds and then release the button. Refer to Figure 4 for a diagram of the buttons.

Note: If your recorder has a **Type A** microprocessor controller PC board installed, then the current range that the recorder is operating in will be altered when this *change range* mode is entered. For example, if the recorder is currently operating in range #1 and the left arrow (#1) button is pressed for the eight second period as described above and then released, the current range will be advanced to range #2 and the LED light will begin flashing two (2) times. Refer to Figure 1A to determine if you have a **Type A** microprocessor controller PC board installed.

The green LED light will begin flashing one (1) time if range #1 is selected or will flash two (2) times if range #2 is selected and so on. Press the left arrow button (#1) to increase the range number or press the

right arrow button (#2) to decrease the range number that is selected for the recorder. When you have finished selecting the range, press and hold the "change chart" button (#3) until the pen begins to move back onto the chart and the selected range will be saved into the recorder's permanent memory.

RECORDER SPECIFICATIONS

INPUT

Nominal Input Voltage: Single Phase 115/230VAC.

Nominal Input Current: 40mA/20mA

Nominal Input Frequency: 50-60 Hz.

BATTERY (Optional)

Battery Type: 9 Volt Alkaline

Low Battery Signaling: Flashing LED

OPERATING ENVIRONMENT

0°C-40°C (32°F-104°F); 0-95% RH, Non-condensing

Pollution Degree: 2

Installation Category: II

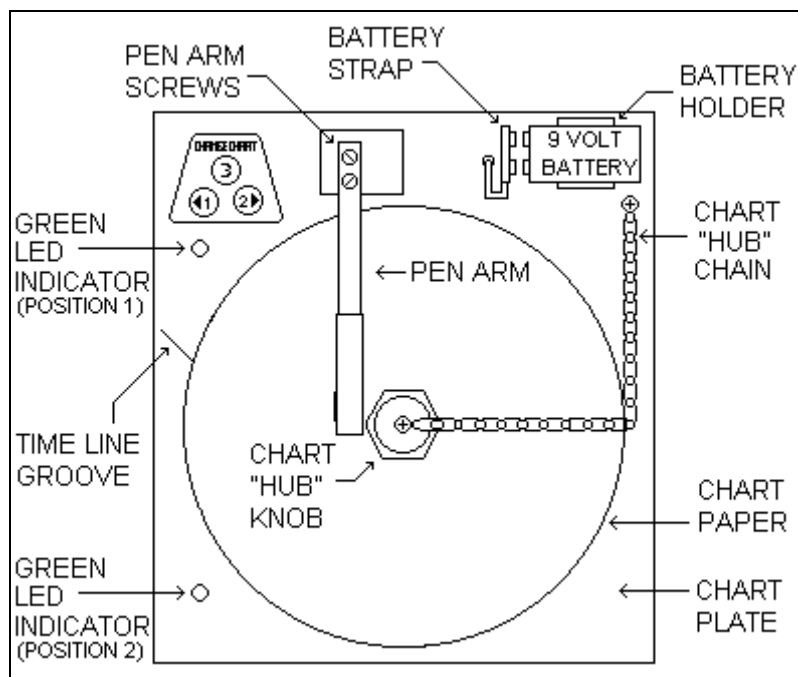

Figure 5: Recorder Assembly (Front View).

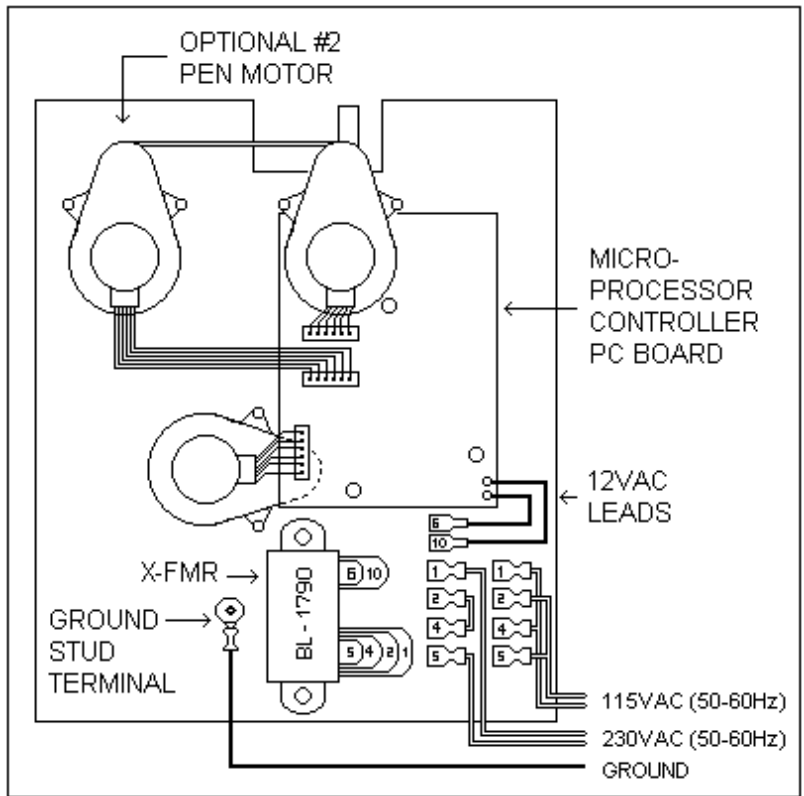

Figure 6A: Recorder Assembly "Type A" (Rear View).

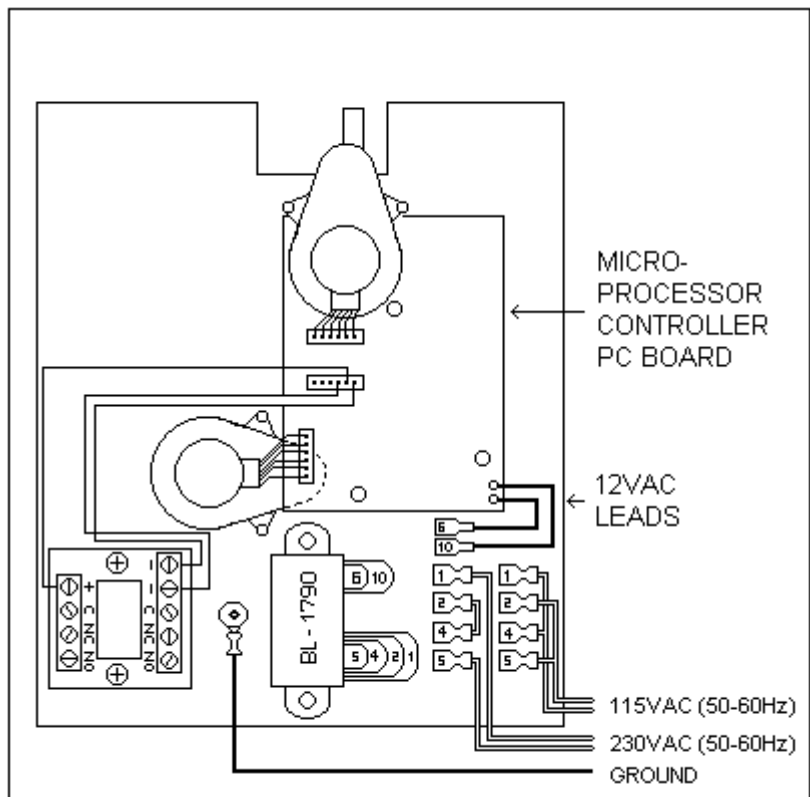

Figure 6B: Recorder Assembly "Type A" with Electric Contact Option (Rear View).

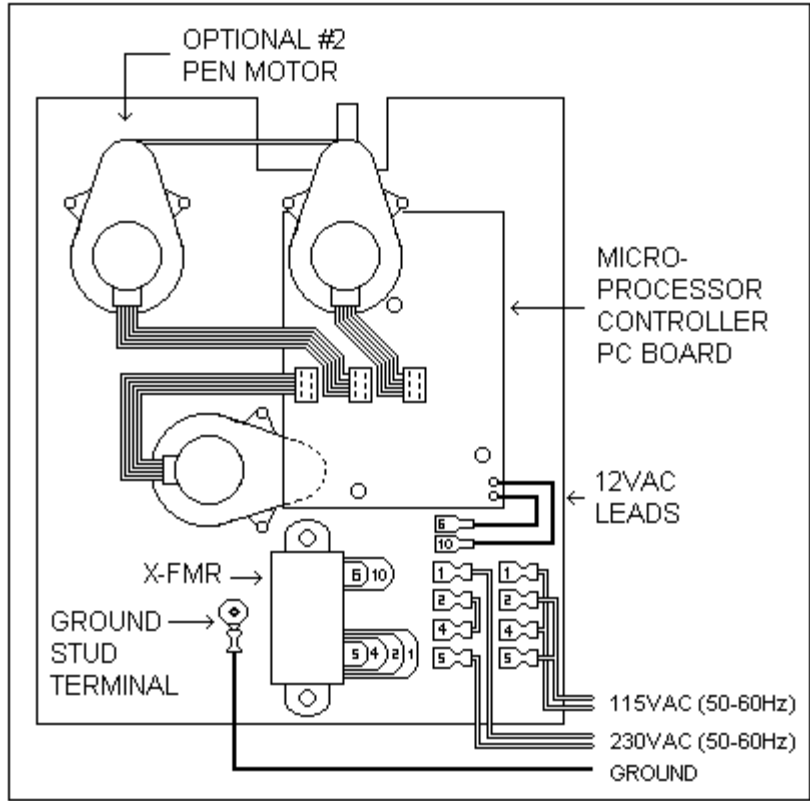

Figure 6C: Recorder Assembly Type "B" (Rear View).

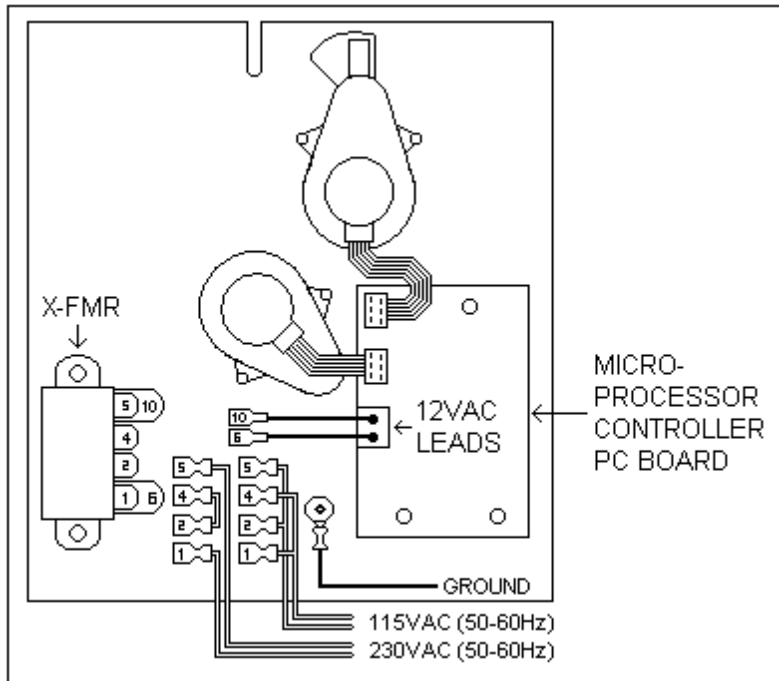

Figure 6D: Recorder Assembly Type "C" (Rear View).

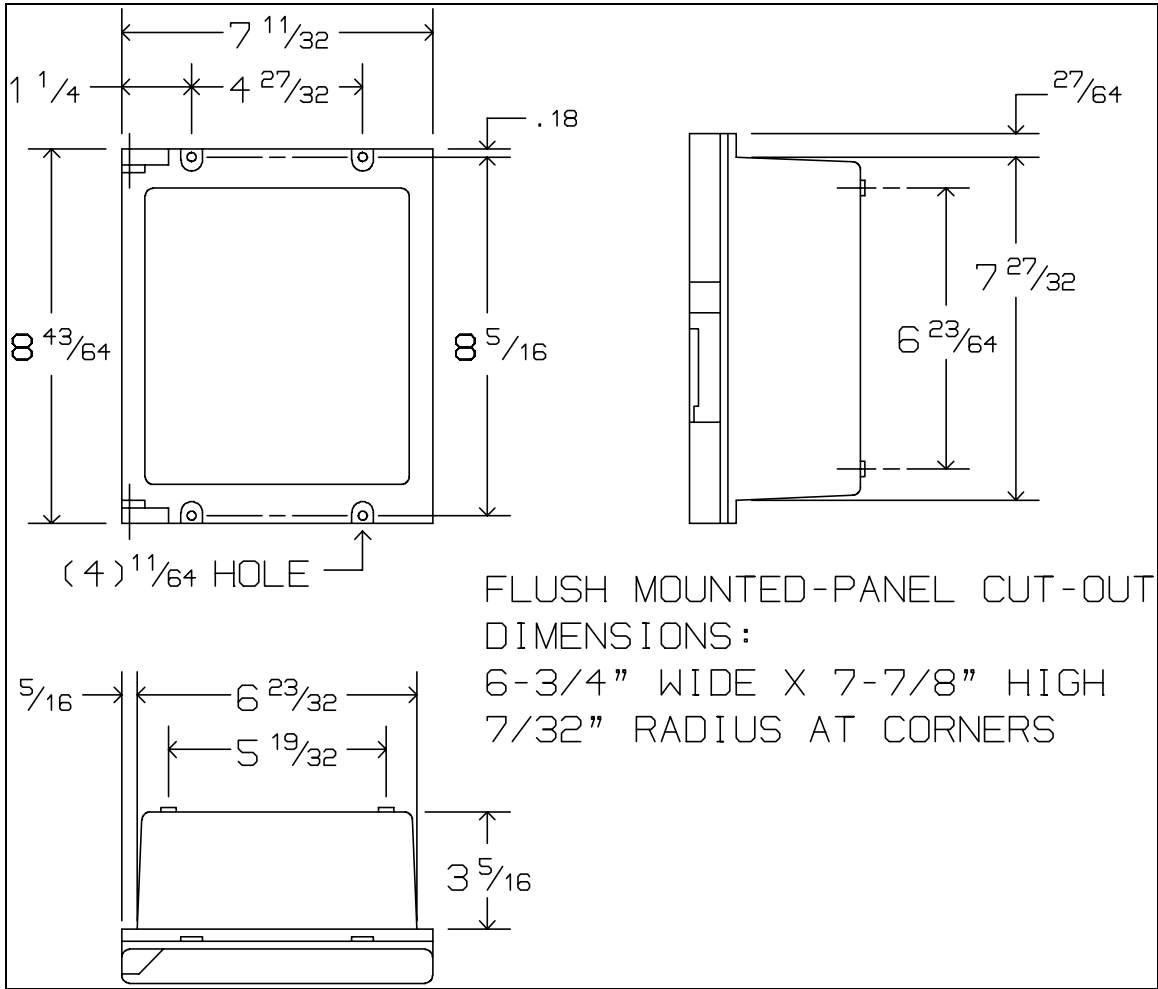

Figure 7: 6" Recorder Case Dimensions.

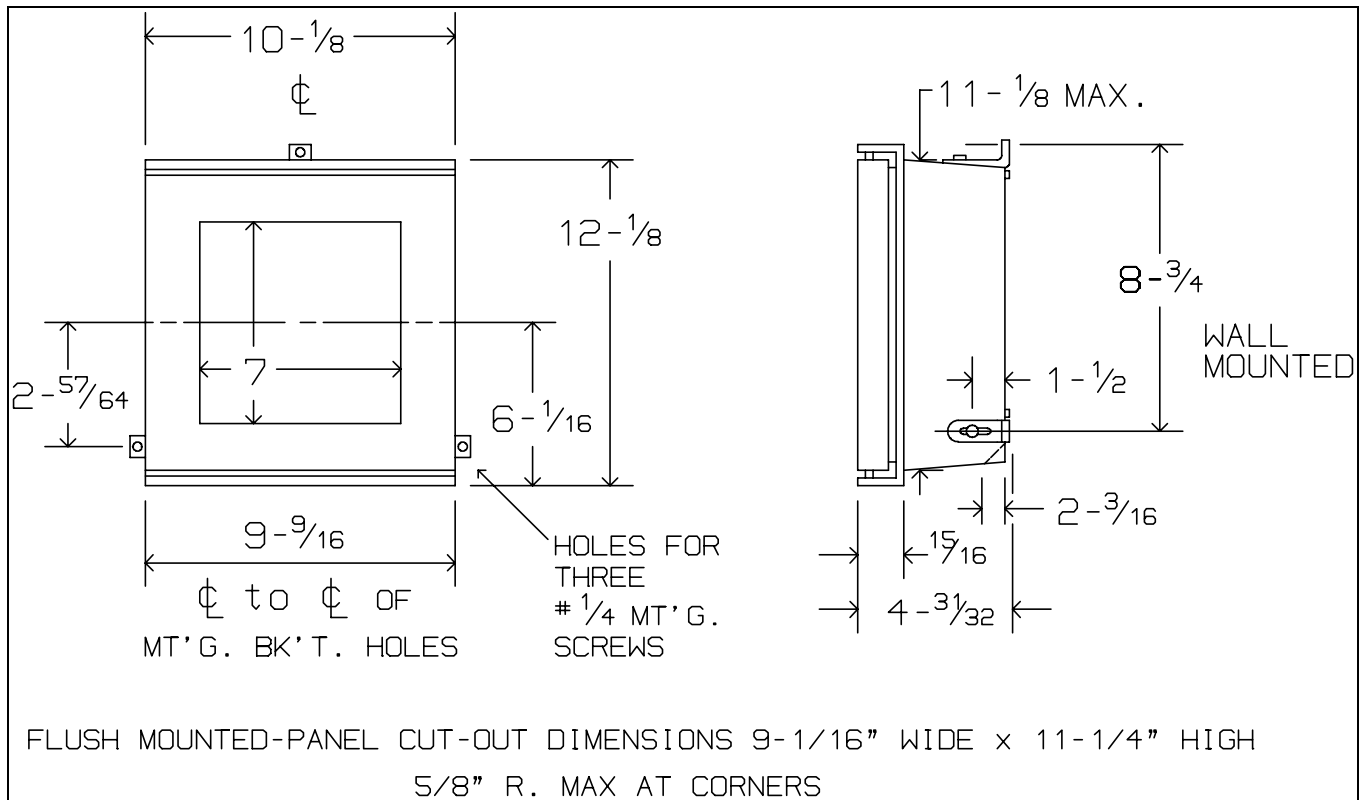

Figure 8: 8" Recorder Case Dimensions.

For all physical dimensions and panel cut-out dimensions for *skeleton* and *skeleton with door* recorders, please contact COBEX Recorders, Inc.

GUARANTEE: COBEX products are warranted to be of good workmanship and quality and free from defects under normal use and service. This warranty is limited to repairing such defects, provided return is made prepaid to COBEX Recorders, Inc., Coconut Creek, Florida within one (1) year after delivery to the original purchaser. COBEX shall not be liable for consequential damages. This warranty is in lieu of all other warranties, guarantees, liabilities or obligations, statutory, expressed or implied to the original purchaser or to any other person. No agent is authorized to assume for COBEX Recorders, Inc., any liability, except as set forth above.

Orders submitted on customer's own purchase order forms, which forms may contain statements, clauses, or conditions modifying, adding to, repugnant to or inconsistent with the terms and provisions of the Seller herein contained will be accepted by the Seller only upon condition and with the express understanding that notwithstanding any such statements, clauses, or conditions contained in any order forms of the customer the liabilities of the Seller shall be determined solely by its own terms and conditions of sale, and in accepting and consummating any such order the Seller shall be deemed not to have in anyway changed, enlarged or modified its liabilities or obligations as fixed by such terms and conditions of sale as stated by the Seller herein.

COBEX CHART RECORDER RECORDING DEVICE ADJUSTMENT

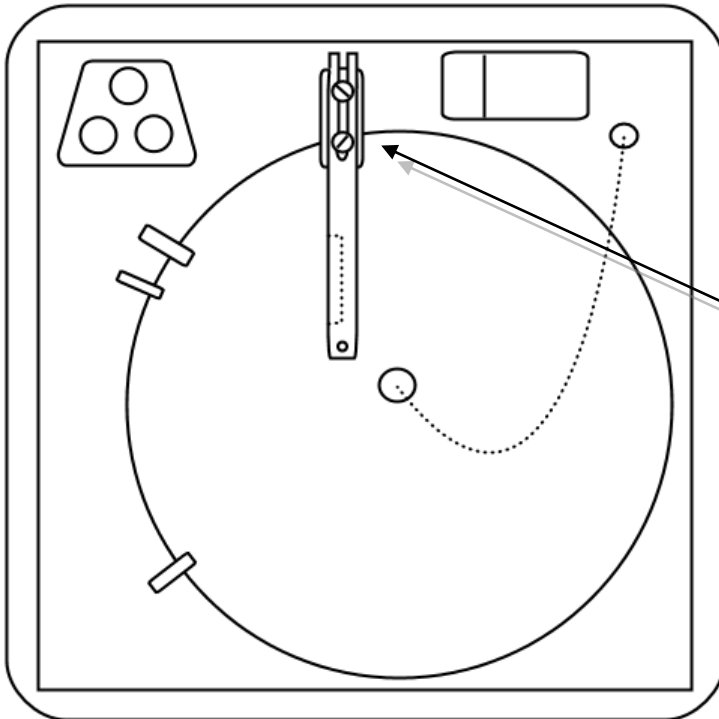

Located on the inside of the chart recorder is a metal "pen" which is used to apply pressure on the carbon paper. To adjust this pressure, it is recommended to complete the following steps to carefully bend the pen to the desired adjustment.

- Using a screwdriver, unscrew the two screws on the recording device, shown here.
- Carefully remove the pen from the recording device.
- Using a flat surface or two hands, gently bend the pen to the desired adjustment (at the bending point) to apply more pressure to the chart paper.

- After the pen is bent, place the adjusted pen back on the chart recorder to measure the adjustment.
- If needed, re-adjust the bending point to the desired adjustment.
- Once completed, re-attach the pen and screws to the recording device.

Note: Avoid bending the metal pen except at bending point (see right). Additional bends could result in warping the metal pen and causing "light" or no markings on the chart recorder paper.

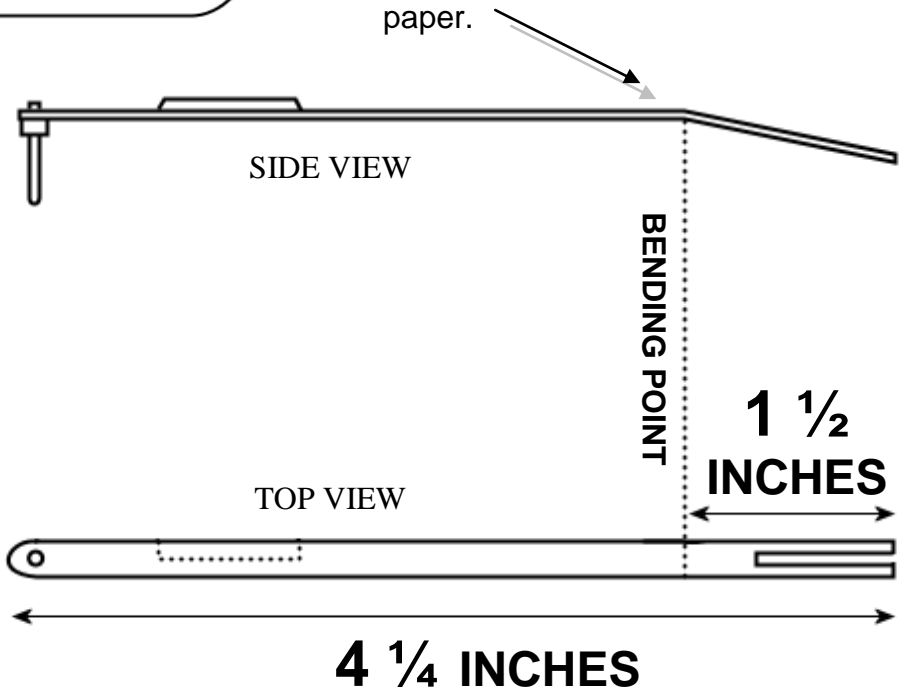

4 1/4 INCHES